



Philips Master LEDtube Value



PHILIPS
sense and simplicity



Master LEDtube Value is a reliable value-for-money LED lamp out of Philips lighting portfolio, incorporates frontier LED chips and other advanced technologies. The product helps customers achieve up to 70% energy saving and significant maintenance cost reduction by comparing to fluorescent lamps. It also helps generate natural and comfortable lighting effect, and to build up green and environment friendly image for our customers.

Product Features

Highly Reliable

- Reliable operation between -20 °C to 45 °C ambient temperature
- Rated average life of 40,000 hours (tested to B50 L70 requirement)
- 50,000 switching cycles

Highly Comfortable

- CRI 80
- Advanced optical design ensures a uniform light output and superior optical efficiency

Highly Energy Efficient

- Energy savings of up to 70%*

* Based on comparison between 20W Master LEDtube Value and Philips TLD standard or super 58W(70W system power when working with Electro Magnetic Ballasts)

Highly Safe

- Protection circuit inside ensuring people's safety in case of mis-use, complying with IEC safety requirements
- Pass 4KV high-pot test, insulation & safety guaranteed
- Pass 1KV surge test (vs. IEC standard 500V), avoiding the damage caused by input voltage fluctuation and lightning strike

Highly Fit

- 100% comply with IEC requirement on T8 dimension, fitting into fluorescent luminaire perfectly

Highly Environmental Friendly

- No mercury and glass
- No breakage and pollution risk

Application

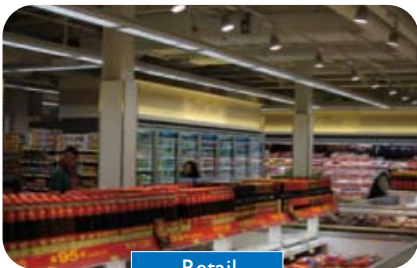

Retail



Industry

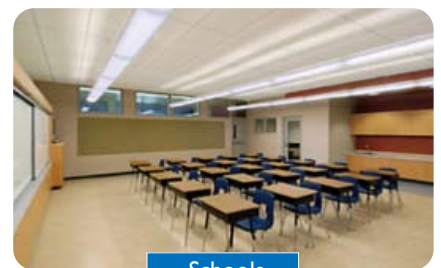

Schools

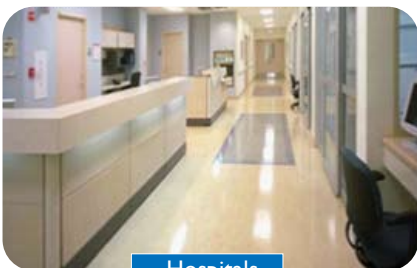

Hospitals

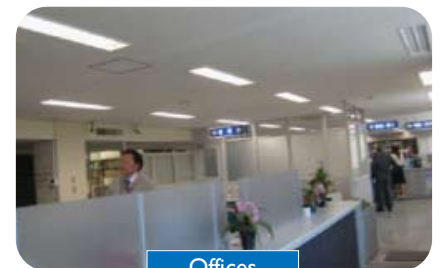

Offices

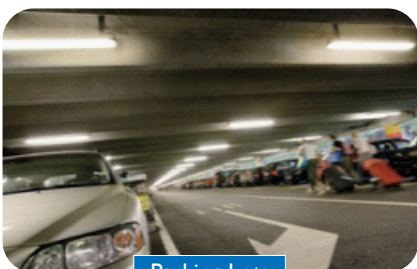

Parking Lots

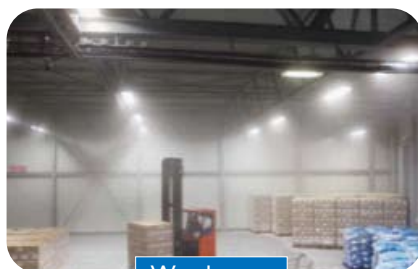

Warehouses

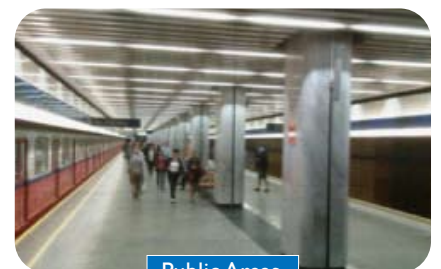

Public Areas

Spectral Power Distribution

Light may be precisely characterized by giving the power of the light at each wavelength in the visible spectrum. The resulting spectralpower distribution (SPD) shows that the Master LEDtube Value contains the visible light only. No harm from UV and IR.

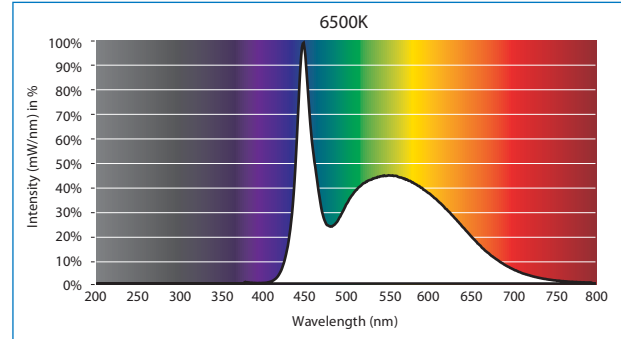
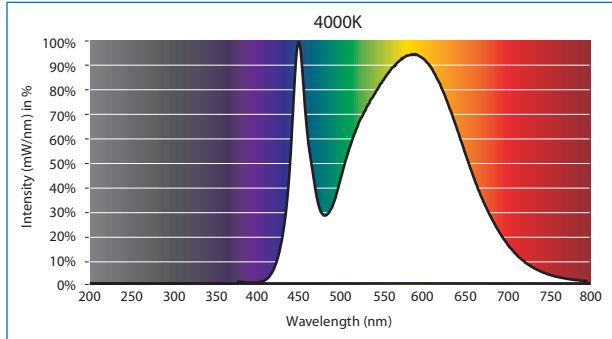

Photometric Diagrams

The Photometric diagram depicting the top down mounted lighting fixtures in a specific area and a numerical grid of the maintained lighting levels that the fixture will produce in that specific area. Pictures below show the photometric diagrams of a typical Philips Master LEDtube's application.

1 x TLED 20W 4000K/6500K

1 x 2000 lm

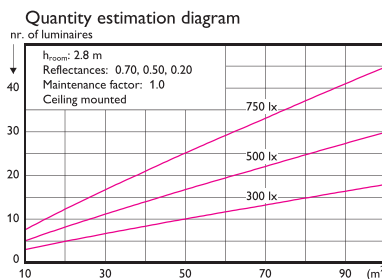
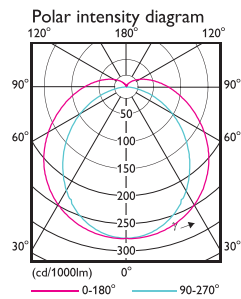

Utilisation factor table

Room Index k	Reflectances (%) for ceiling, walls and working plane (CIE)											
	0.80	0.80	0.70	0.70	0.70	0.70	0.50	0.50	0.30	0.30	0.30	0.00
0.30	0.10	0.10	0.30	0.20	0.10	0.10	0.10	0.10	0.10	0.10	0.10	0.00
0.60	0.44	0.42	0.43	0.42	0.41	0.34	0.32	0.28	0.31	0.27	0.24	0.00
0.80	0.54	0.51	0.53	0.51	0.50	0.42	0.40	0.35	0.39	0.34	0.31	0.00
1.00	0.63	0.58	0.61	0.58	0.57	0.49	0.47	0.42	0.45	0.41	0.37	0.00
1.25	0.71	0.65	0.68	0.66	0.63	0.56	0.54	0.48	0.51	0.47	0.43	0.00
1.50	0.77	0.70	0.74	0.71	0.68	0.61	0.59	0.54	0.56	0.52	0.48	0.00
2.00	0.87	0.77	0.83	0.79	0.75	0.69	0.66	0.62	0.63	0.60	0.55	0.00
2.50	0.93	0.82	0.89	0.84	0.80	0.75	0.71	0.67	0.68	0.65	0.60	0.00
3.00	0.98	0.86	0.94	0.88	0.83	0.79	0.75	0.72	0.72	0.69	0.64	0.00
4.00	1.04	0.90	0.99	0.93	0.88	0.84	0.80	0.77	0.77	0.74	0.69	0.00
5.00	1.08	0.93	1.03	0.96	0.90	0.87	0.83	0.80	0.83	0.80	0.77	0.00

Luminance Table

Plane Cone	0.0	15.0	30.0	45.0	60.0	75.0	90.0
45.0	7134	6950	6999	7298	7887	8898	10568
50.0	6662	6448	6467	6736	7294	8304	10083
55.0	6177	5948	5949	6201	6700	7665	9500
60.0	5719	5475	5459	5691	6119	7023	8902
65.0	5279	5023	4990	5202	5538	6338	8203
70.0	4868	4603	4557	4752	4992	5541	7146
75.0	4520	4248	4193	4376	4653	4881	6371
80.0	4196	3918	3854	4028	3957	4123	5113
85.0	3901	3621	3554	3728	3502	3339	3003
90.0	3645	3359	3286	3459	3231	3047	1046

Lifetime and Lumen Maintenance

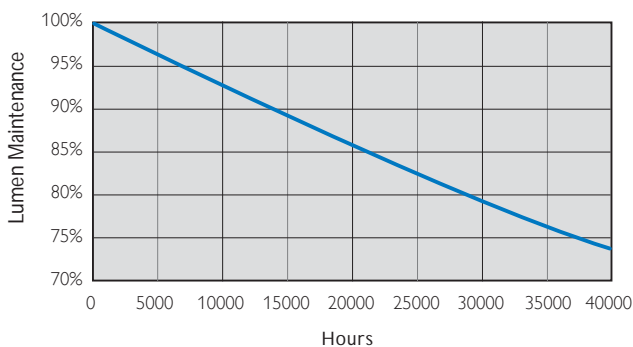

PHILIPS Master LEDtube Value has a lifetime of 40,000 hours, defined as the number of hours when 50% of a large group of identical lamps below 70% of its initial lumens.

Temperature

Master LEDtube's excellent thermal design ensures low temperature during operating, which brings reliable and stable product performance throughout life time.

Operating temperature	T _{operating}	min -20°C	max +45°C
Storage temperature	T _{storage}	min -40°C	max +65°C
Maximum case temperature of tube at Tamb.=25°C	T _{case}		+50°C

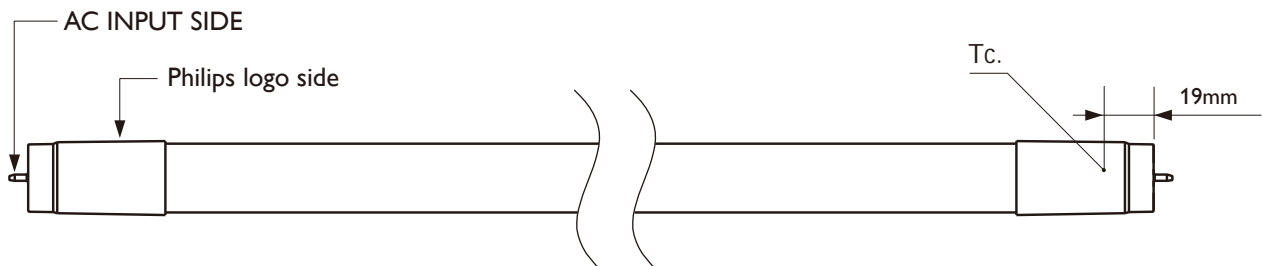
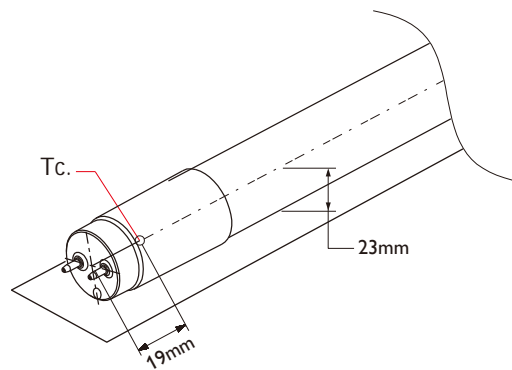
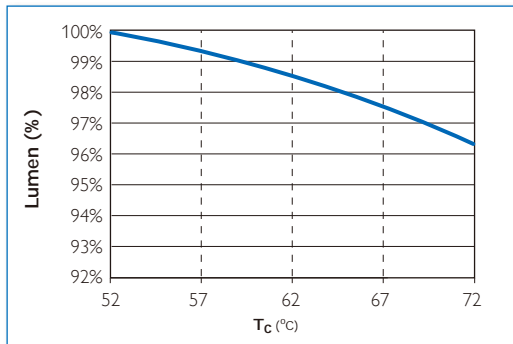

Approbation & Certificates

Philips Essential LEDtube is designed by strictly following applicable legislation and international standard. The product complies with **CE, KEMA, TISI, RCM, RoHS** and **REACH**.



Technical specification

10NC	Product Description	Wattage	Equivalent Fluorescent Wattage	Voltage	Cap	Length	Lifetime	Lumen output (Typical)	Lumen output (Maximal)	Color Temp	CRI
		(W)	(W)	(V)		(mm)	(hrs)	(lm)	(lm)	(K)	(Typical*)
9290002876	MAS LEDtube VLE 1500mm 20W840 T8C	20	58	220-240	G13	1500	40000	2000	2200	4000	83
9290002877	MAS LEDtube VLE 1500mm 20W865 T8C	20	58	220-240	G13	1500	40000	2000	2200	6500	83

*Minimum CRI is 80

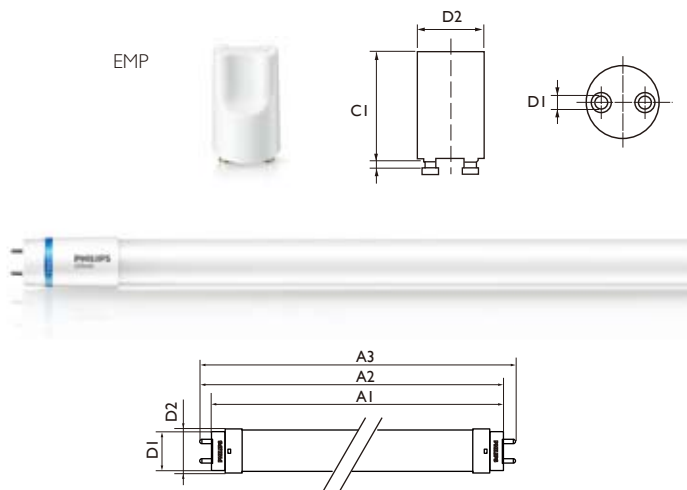

Accessories

MASTER LEDtube

Protector EMP

Dimensions (mm)

Product	A1	A2	A3	C1	D1	D2
1500mm	1498.7	1505.8	1512.9	-	25.68	28
EMP	-	-	-	34.5	3	21.5

Quick Installation Guide

Please take the time to read this quick installation guide. Philips Lighting does not accept liability for any damages for installations not performed according to this guide or not performed by a professional electrician.

Installation Warning

- Check whether the system is an EM (Electro Magnetic) ballast based system or an HF (High Frequency electronic) ballast based system, and follow the appropriate instructions accordingly. For new built luminaires follow section "New built luminaires".
- Product is not dimmable
- Always switch off the power supply before commencing work
- Do not change the structure or any components of the product

Application Notes

- Operation temperature range is between -20°C and +45°C ambience.
- Only to apply in dry indoor usage and environments.
- Not intended for use with emergency light fixtures or exit light.
- For use in fixtures which consist of IEC compliant G13 bi-pin lamp holders which can support 500 gram.

Installation Guide

• EM ballast based system

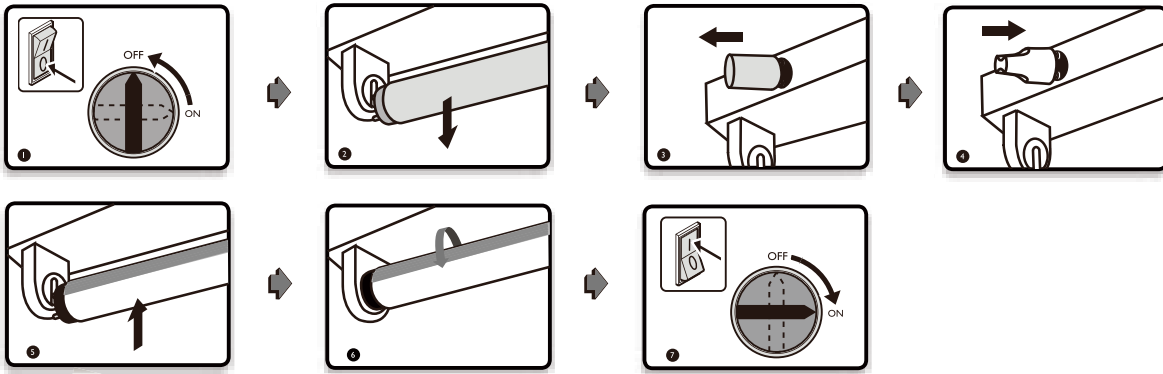

• HF ballast based system

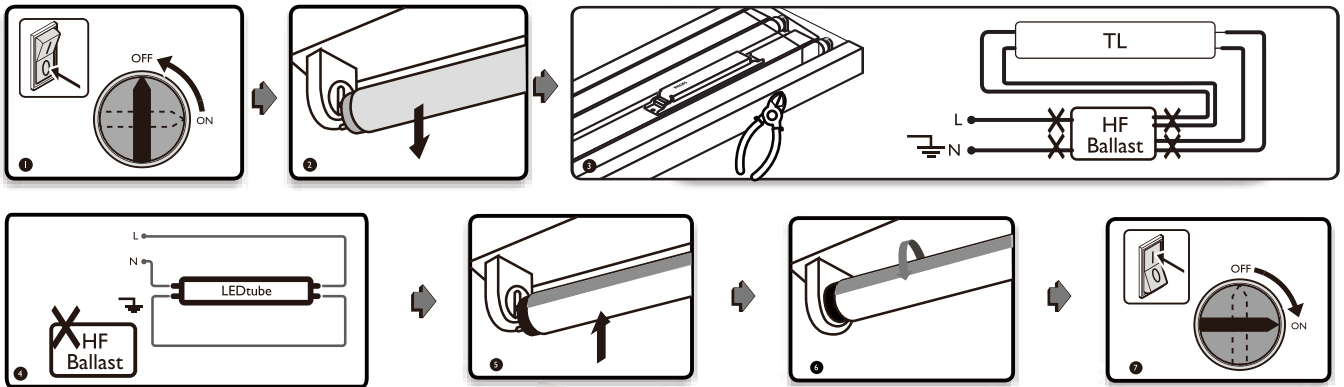

Note: for twin lamp series configuration and more detailed information please visit:
www.philips.com/led-product-info

OEM Guideline

Lifetime vs. Failure Rate @ Ta 25 °C

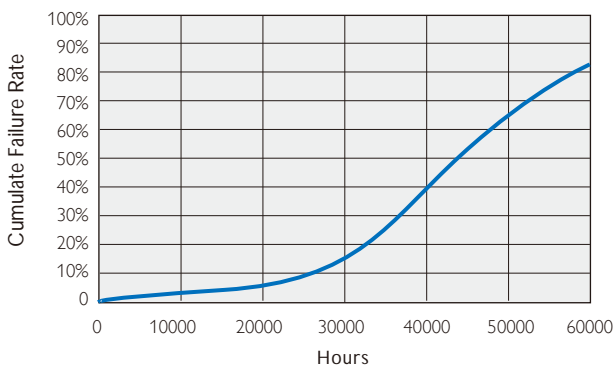

Lifetime and Lumen Maintenance

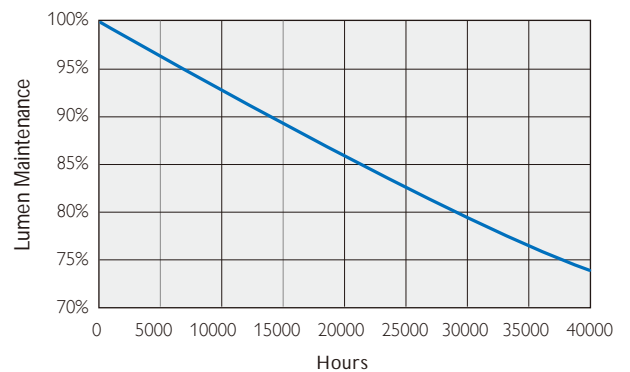

Failure Rate vs.
Lifetime vs. Tcase

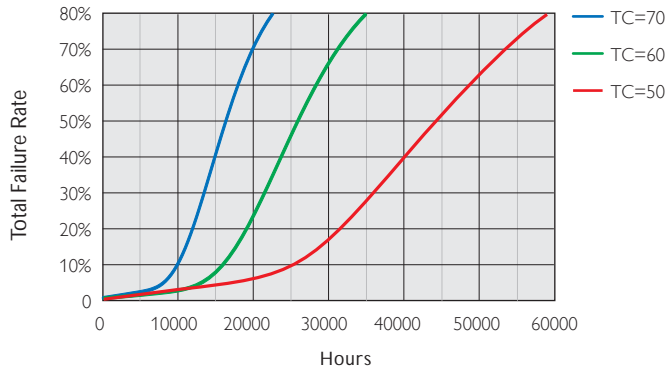

Lifetime vs. Tcase

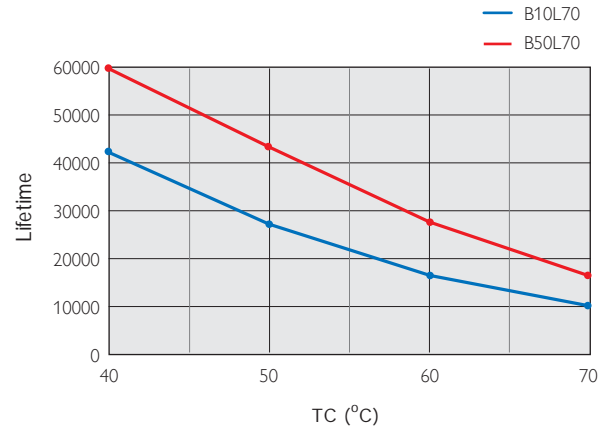

© 2014 Philips Lighting

All rights reserved. Reproduction in whole or in part is prohibited without the prior written consent of the copyright owner. The information presented in this document does not form part of any quotation or contract, is believed to be accurate and reliable and may be changed without notice. No liability will be accepted by the publisher for any consequence of its use. Publication thereof does not convey nor imply any license under patent or other industrial or intellectual property rights.

03/2014
www.philips.com